

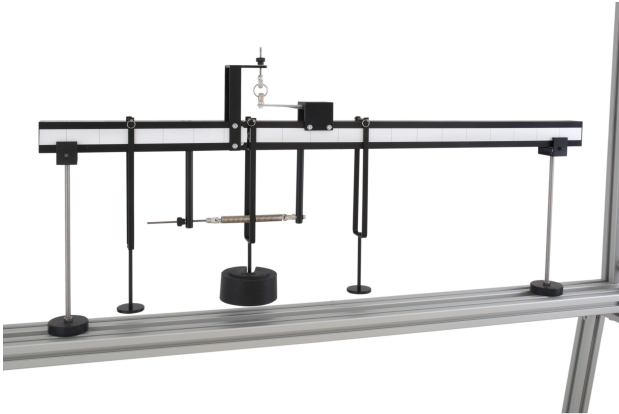

SHEAR FORCE in a BEAM

HST9



Year 1
study

Features

- Visually realistic, 'cut' beam
- Takes internal forces and shows them externally
- Shear Force output via load cell
- Unrestricted loading positions
- Load position at 'cut' in beam
- Experiment can be undertaken from both sides
- Quickly and easily interchangeable with HST10 and HST46
- Optional Influence line section
- Optional HSTS Software
- Dedicated e-book supplied

Description

Each beam is simply supported on vertical supports which can be easily moved to create varying beam spans. At the 'cut' section, bearings in one beam

straddle a vertical bearing track in the mating beam. This ensures free vertical movement for monitoring shear forces. Although beam bending is permitted, it is counteracted by the bearings and a tension spring supported horizontally from underneath the beams.

The force transducer is supplied with a connection lead to connect its output directly into the HDA200 Interface (sold separately). Special Load hangers are provided that fit over the beams. The Load hangers can be positioned accurately along each beams length by using the graduated scales attached to the side of the beams.

Related laws

- Shear Force
- Strain
- Stress
- Young's' Modulus

- Shear Force Diagrams (SFD)
- Verification of Equilibrium of Vertical Forces and Moments

Learning capabilities

- Visual demonstration of shear force at a 'cut' in a beam
- Comparison of experimental results with theory
- Creation and use of shear force diagrams
- Shear force variation with varying point loads, load positions and load arrangements
- Use of force transducer to monitor shear force

Technical Specification

- Beam lengths of 650 and 350mm
- Beam cross section: 51 x 38mm
- 50mm graduations on beams
- Weights set: 1 x 2N, 1 x 5N, 2 x 10N

Essential Ancillaries

- HST1 (or HST100)
- HDA200

Recommended Ancillaries

- HST9A
- HSTS

What's in the Box?

- 1 x Short Beam
- 1 x Long Beam
- 2 x Support Rods
- 3 x Hangers
- 1 x 2N, 1 x 5N, 2 x 10N weight
- 1 x Tape measure
- Accessories container
- Hex wrench
- Instruction manual
- E-book
- Packing list
- Test sheet

You might also like

- HST10
- HST46
- HFC31

Supporting Software

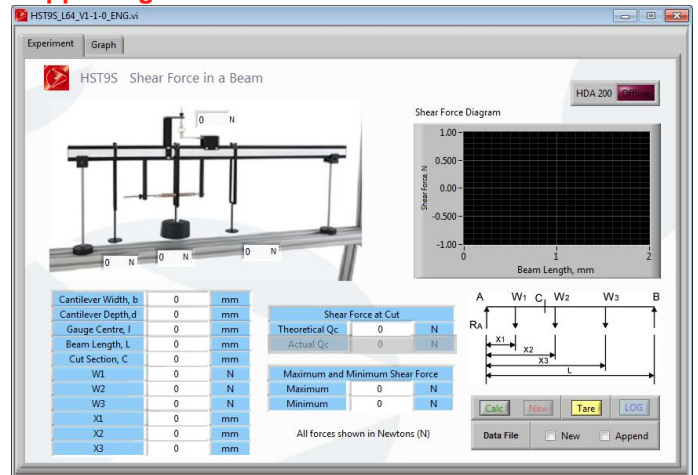

- HSTS Structures Experimental Software Package
- The HST9S comes supplied as part of the HSTS Structures Experimental Software Package
- The HST9S software allows the student to see the differences between the theoretical and reality of the experimental set-up
- This software works both on and off line and can be used as part of a student lecture to help guide students through the learning process

Minimum System Requirements

- See HSTS Specification

Weights & Dimensions

- Weight: 6 kg
- Length: 1000mm
- Width: 600mm
- Height: 300mm

Essential Services

- 110/120V, 60Hz or 220/240V, 50Hz, single phase, live neutral and earth for HDA200

Operational Conditions

All brand and/or product names are trademarks of their respective owners. Specifications and external appearance are subject to change without notice. The colour of the actual product may vary from the colour shown in the brochure.

Copyright © 2018 P.A. Hilton Limited. All rights reserved. This technical leaflet, its contents and/or layout may not be modified and/or adapted, copied in part or in whole and/or incorporated into other works without the prior written permission of P. A.

Hilton Limited. Hi-Tech Education is a registered trade mark of P. A. Hilton Limited.

COUNTRY OF ORIGIN - UK WARRANTY PERIOD - 2 YEARS

- Storage temperature: -10°C to +70°C
- Operating temperature range: +10°C to +50°C
- Operating relative humidity range: 0 to 95%, non condensing

Ordering information

To order this product, please call PA Hilton quoting the following code:

HST9

All brand and/or product names are trademarks of their respective owners. Specifications and external appearance are subject to change without notice. The colour of the actual product may vary from the colour shown in the brochure.

Copyright © 2018 P.A. Hilton Limited. All rights reserved. This technical leaflet, its contents and/or layout may not be modified and/or adapted, copied in part or in whole and/or incorporated into other works without the prior written permission of P. A. Hilton Limited. Hi-Tech Education is a registered trade mark of P. A. Hilton Limited.

COUNTRY OF ORIGIN - UK WARRANTY PERIOD - 2 YEARS